

PRODUCT SPECIFICATION



High Power DMX Decoder&driver

Model: PX403(RJ45 INTERFACE)

Meets DMX512/1990

MAX 3A/CH Output

Apply to all kinds of LED Driver

SUMMARIZE

Thank you for using PX series of DMX512 Decoder. PX series adopt the advanced micro-computer control technology, it converts the DMX-512/1990 standard digital signal adopted widely in international to the analog control signal. Output 1~4 Channels for option and each channel able to achieve 256 levels of brightness controlling, and also it can be used as the connector of PC digital-light controller and analog light modulator. It is mainly used for the controlling of buildings & lights applied LED.

Product Features

- ◆ Meets DMX512/1990
- ◆ 256-levels brightness, full-color with driver controls
- ◆ Output 4 channels, max 3A per channel.
- ◆ Can achieve asynchronous color changes effect under working with controller.
- ◆ With the light color selected mechanism, and be able to control the light with 1~4 colors;
- ◆ Setting the DMX address freely
- ◆ Modularizing and can be matched with different LED module neatly
- ◆ Custom-made

Tech-parameter

Decode CH.	1-4 CH
Signal Input:	DMX-512/1990 Digital signal
Signal output:	0~V+(V+ is power supply) max 3A/ch output drive
Power supply:	DC, +12~24V
Power Dis.:	<1W
Power output:	<280W
Work Temp.:	0~70°C
Size:	175(mm)*41.5(mm)*33.5(mm) /Custom-made
Packing size:	18(mm)*43(mm)*38(mm)
Net Weight:	242.5g
Gross weight:	255g

DIMENSION

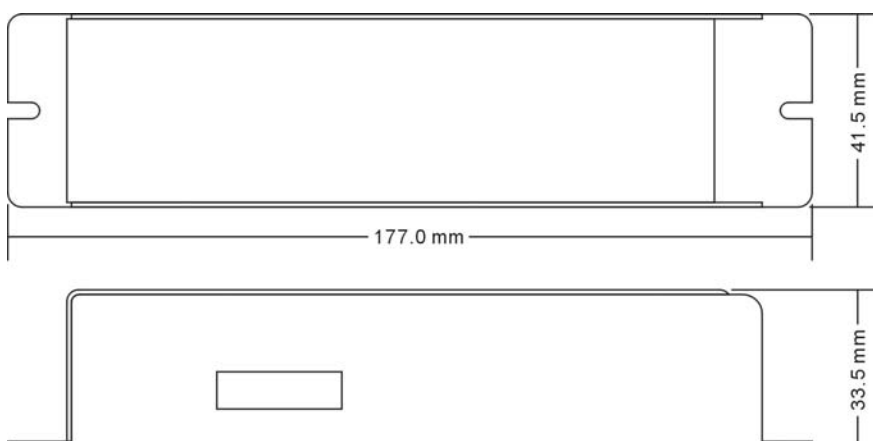

Internal Block Diagram

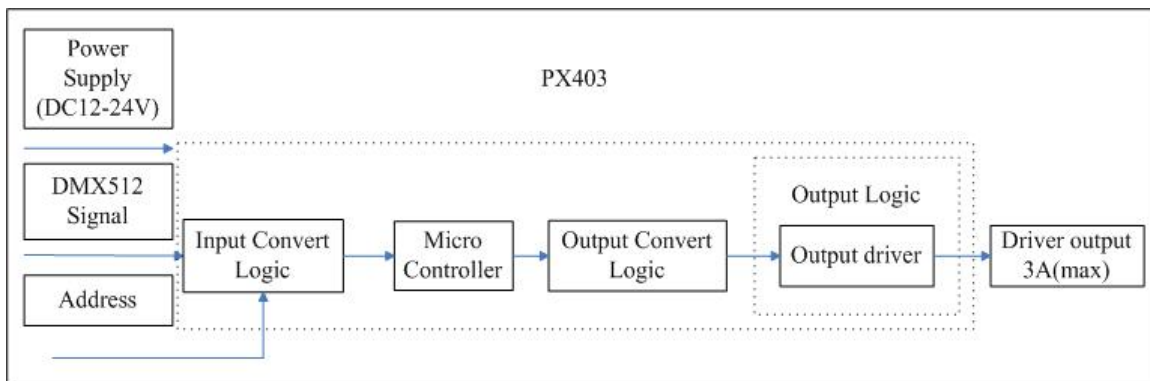

Appearance

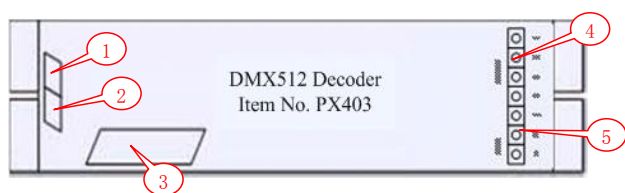

- (1) 、 (2) DMX signal input&output interface(RJ45)
- (3) Address setting interface
- (4) Driver output interface
- (5) Power input interface

Interface Introduction

- ◆ DMX signal interface

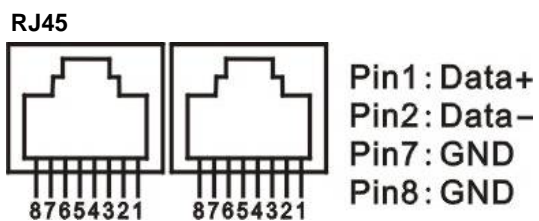

- ◆ Address code setting on/off
Please see the operating instruction details as "DMX series of addresses dial code table "
- ◆ Power Input Interface
DC 12~24V input, supplied power with the decoder and the lamps it takes.
- ◆ Driver output interface
Common anode,V+ and R,G,B interface, can drive kinds of RGB module or single-color module, Can regulate output current according to the actual load.

Remark:

Connect the anode and RGB wire of common anode RGB module to the output interface of decoder directly;
 Connect the anode wire of single-color module to V+ on decoder,and connect the cathode wire to one of RGB pin according to the LED's color; Connect several colors single-color module to one decoder,please connect their anode wires to V+ pin on decoder.

Operating instruction

PX403 Decoder is controlled by DMX-512, and its fore-end connect with the DMX512 signal transmit device. Take EC-DMX512 for example, its rear-end can connect with 0~24V circuit signal device. This instruction is only for LED driver. The connecting diagram is as following.

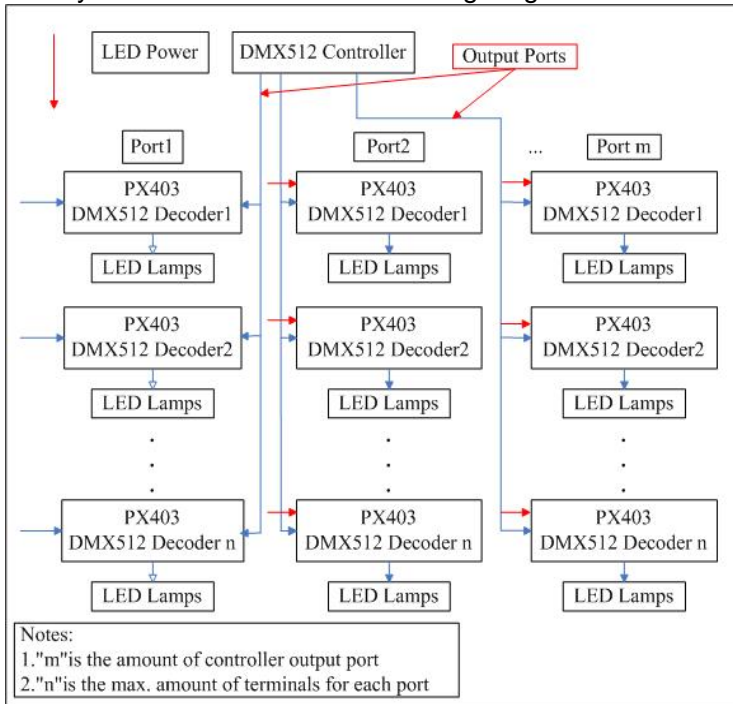

TYPICAL APPLICATIONS

◆ Circuit Diagram 1

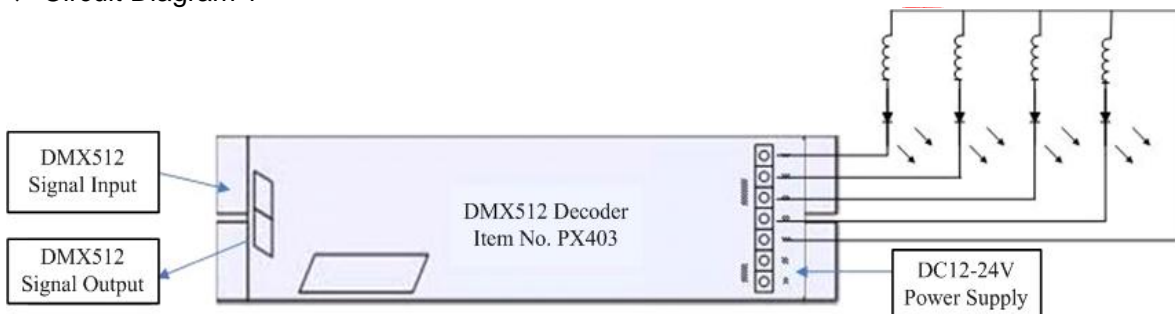

Connecting of DMX-512 Signal Cable

- ◆ DMX signal cable used the CAT-5 cable, and DMX signal tells positive(+) from negative (-). While weldin the DMX signal cable plug, there must pay much attention to know postive(+) from negative(-), and then connect the DMX512 signal cable with the corresponding input interface of PX403 correctly.
- ◆ Connect a signal terminal at the end of the whole conenction.